

A
B
C
D
E

SECTION **BR** BRAKE SYSTEM

CONTENTS

<p>PRECAUTIONS 3</p> <p style="padding-left: 20px;">Precautions for Supplemental Restraint System (SRS) "AIR BAG" and "SEAT BELT PRE-TENSIONER" 3</p> <p style="padding-left: 20px;">Precautions for Brake System 3</p> <p>PREPARATION 4</p> <p style="padding-left: 20px;">Commercial Service Tools 4</p> <p>NOISE, VIBRATION AND HARSHNESS (NVH)</p> <p>TROUBLESHOOTING 5</p> <p style="padding-left: 20px;">NVH Troubleshooting Chart 5</p> <p>BRAKE PEDAL 6</p> <p style="padding-left: 20px;">Inspection and Adjustment 6</p> <p style="padding-left: 40px;">PLAY AND CLEARANCE BETWEEN BRAKE PEDAL AND FLOOR PANEL WITH PEDAL DEPRESSED. 6</p> <p style="padding-left: 40px;">ADJUSTMENT 7</p> <p style="padding-left: 20px;">Removal and Installation 7</p> <p style="padding-left: 40px;">COMPONENT PARTS LOCATION 7</p> <p style="padding-left: 40px;">REMOVAL 8</p> <p style="padding-left: 40px;">INSPECTION AFTER REMOVAL 8</p> <p style="padding-left: 40px;">INSTALLATION 8</p> <p>BRAKE FLUID 9</p> <p style="padding-left: 20px;">Checking Brake Fluid Level 9</p> <p style="padding-left: 20px;">Checking Brake Line 9</p> <p style="padding-left: 20px;">Drain and Refill 9</p> <p style="padding-left: 20px;">Bleeding Brake System 10</p> <p>BRAKE PIPING AND HOSE 11</p> <p style="padding-left: 20px;">Hydraulic Circuit 11</p> <p style="padding-left: 20px;">Front Brake Piping and Hose 11</p> <p style="padding-left: 40px;">REMOVAL 11</p> <p style="padding-left: 40px;">INSTALLATION 11</p> <p style="padding-left: 20px;">Rear Brake Piping and Hose 12</p> <p style="padding-left: 40px;">REMOVAL 12</p> <p style="padding-left: 40px;">INSTALLATION 12</p> <p style="padding-left: 20px;">Inspection After Installation 12</p> <p>BRAKE MASTER CYLINDER 13</p> <p style="padding-left: 20px;">Components 13</p> <p style="padding-left: 20px;">Removal and Installation 13</p> <p style="padding-left: 40px;">REMOVAL 13</p>	<p style="padding-left: 20px;">INSTALLATION 13</p> <p style="padding-left: 20px;">Disassembly and Assembly 14</p> <p style="padding-left: 40px;">DISASSEMBLY 14</p> <p style="padding-left: 40px;">INSPECTION AFTER DISASSEMBLY 15</p> <p style="padding-left: 40px;">ASSEMBLY 15</p> <p>BRAKE BOOSTER 18</p> <p style="padding-left: 20px;">On-Vehicle Service 18</p> <p style="padding-left: 40px;">OPERATING CHECK 18</p> <p style="padding-left: 40px;">AIRTIGHT CHECK 18</p> <p style="padding-left: 20px;">Removal and Installation 18</p> <p style="padding-left: 40px;">REMOVAL 18</p> <p style="padding-left: 40px;">INSPECTION AFTER REMOVAL 19</p> <p style="padding-left: 40px;">INSTALLATION 19</p> <p>VACUUM LINES 20</p> <p style="padding-left: 20px;">Removal and Installation 20</p> <p style="padding-left: 20px;">Inspection 20</p> <p style="padding-left: 40px;">VISUAL INSPECTION 20</p> <p style="padding-left: 40px;">CHECK VALVE INSPECTION 20</p> <p>FRONT DISC BRAKE 21</p> <p style="padding-left: 20px;">Components 21</p> <p style="padding-left: 20px;">Inspection 22</p> <p style="padding-left: 40px;">PAD THICKNESS 22</p> <p style="padding-left: 20px;">Pad Replacement 22</p> <p style="padding-left: 40px;">REMOVAL 22</p> <p style="padding-left: 40px;">INSTALLATION 23</p> <p style="padding-left: 20px;">Caliper Removal and Installation 23</p> <p style="padding-left: 40px;">REMOVAL 23</p> <p style="padding-left: 40px;">INSTALLATION 23</p> <p style="padding-left: 20px;">Caliper Disassembly and Assembly 24</p> <p style="padding-left: 40px;">DISASSEMBLY 24</p> <p style="padding-left: 40px;">INSPECTION AFTER DISASSEMBLY 24</p> <p style="padding-left: 40px;">DISC ROTOR INSPECTION 24</p> <p style="padding-left: 40px;">ASSEMBLY 25</p> <p style="padding-left: 20px;">Brake Burnishing Procedure 26</p> <p>REAR DISC BRAKE 27</p> <p style="padding-left: 20px;">Component 27</p> <p style="padding-left: 20px;">Inspection 28</p> <p style="padding-left: 40px;">PAD THICKNESS 28</p> <p style="padding-left: 20px;">Pad Replacement 28</p> <p style="padding-left: 40px;">REMOVAL 28</p>
---	---

BR
G
H
I
J
K
L
M

INSTALLATION	29	SERVICE DATA AND SPECIFICATIONS (SDS)	33
Caliper Removal and Installation	29	General Specifications	33
REMOVAL	29	Brake Pedal	33
INSTALLATION	29	Check Valve	33
Caliper Disassembly and Assembly	30	Brake Booster	33
DISASSEMBLY	30	Front Disc Brake	33
INSPECTION AFTER DISASSEMBLY	30	Rear Disc Brake	34
DISC ROTOR INSPECTION	31		
ASSEMBLY	31		

PRECAUTIONS

PRECAUTIONS

PFP:00001

Precautions for Supplemental Restraint System (SRS) “AIR BAG” and “SEAT BELT PRE-TENSIONER”

AFS0021U

The Supplemental Restraint System such as “AIR BAG” and “SEAT BELT PRE-TENSIONER”, used along with a front seat belt, helps to reduce the risk or severity of injury to the driver and front passenger for certain types of collision. This system includes seat belt switch inputs and dual stage front air bag modules. The SRS system uses the seat belt switches to determine the front air bag deployment, and may only deploy one front air bag, depending on the severity of a collision and whether the front occupants are belted or unbelted. Information necessary to service the system safely is included in the SRS and SB section of this Service Manual.

WARNING:

- To avoid rendering the SRS inoperative, which could increase the risk of personal injury or death in the event of a collision which would result in air bag inflation, all maintenance must be performed by an authorized NISSAN/INFINITI dealer.
- Improper maintenance, including incorrect removal and installation of the SRS, can lead to personal injury caused by unintentional activation of the system. For removal of Spiral Cable and Air Bag Module, see the SRS section.
- Do not use electrical test equipment on any circuit related to the SRS unless instructed to in this Service Manual. SRS wiring harnesses can be identified by yellow and/or orange harnesses or harness connectors.

Precautions for Brake System

AFS00076

- Recommended fluid is brake fluid “DOT 3”.
- Never reuse drained brake fluid.
- Be careful not to splash brake fluid on painted areas.
- To clean or wash all parts of master cylinder, disc brake caliper and wheel cylinder, use clean brake fluid.
- Never use mineral oils such as gasoline or kerosene. They will ruin rubber parts of the hydraulic system.
- Use flare nut wrench when removing and installing brake tube.
- Always tighten brake lines to the specified torque when installing.
- Before working, turn ignition switch OFF and disconnect connectors for VDC actuator or battery negative terminal.
- Burnish the brake contact surfaces after refinishing or replacing drums or rotors, after replacing pads or linings, or if a soft pedal occurs at very low mileage. Refer to [BR-26, "Brake Burnishing Procedure"](#).

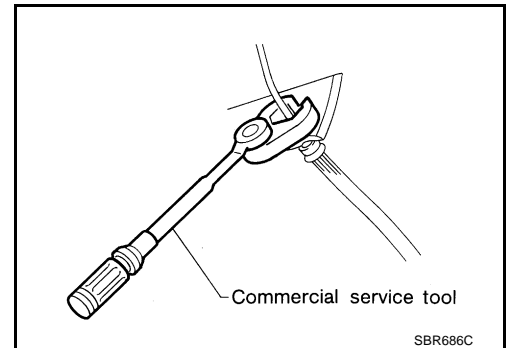

WARNING:

- Collect dust on brake parts with dust collector. Do not blow off the dust.

PREPARATION

PREPARATION

PFP:00002

Commercial Service Tools

AFS0011A

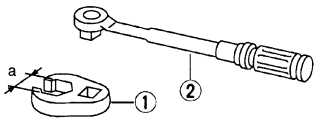
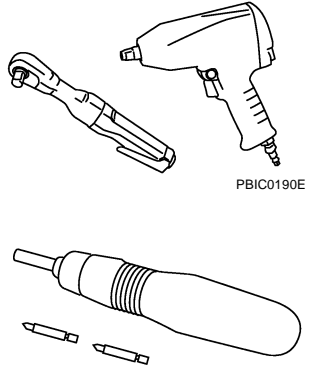
Tool name	Description
<p>1. Flare nut crowfoot a:10 mm (0.39 in) (Other) a:12 mm (0.47 in) (Between VDC actuator and master cylinder)</p> <p>2. Torque wrench</p>	 <p>S-NT360</p> <p>Removing and installing each brake piping</p>
<p>Power tool</p>	 <p>PBIC0190E</p> <p>PBIC0191E</p> <p>Removing front and rear caliper assembly</p>

BRAKE PEDAL

BRAKE PEDAL

PFP:46501

Inspection and Adjustment

AFS00006

PLAY AND CLEARANCE BETWEEN BRAKE PEDAL AND FLOOR PANEL WITH PEDAL DEPRESSED.

1. Check brake pedal height from dash floor panel.
2. Adjust the height referring to the following specifications.

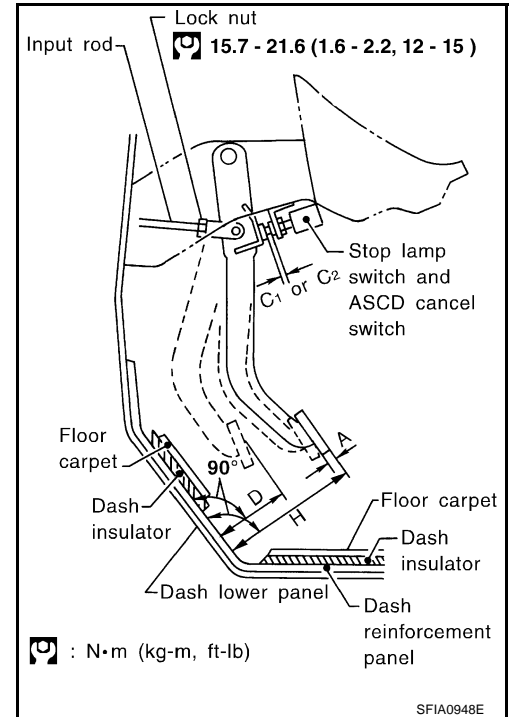

H	Brake pedal free height (from dash panel top surface)	M/T model	154 - 164 mm (6.06- 6.46 in)
		A/T model	162 - 172 mm (6.38 - 6.77 in)
D	Brake pedal depressed height (under a force of 490 N (50 kg, 110 lb) with the engine running)	M/T model	More than 90 mm (3.54 in)
		A/T model	More than 95 mm (3.74 in)
C1 or C2	Clearance between stopper rubber and the threaded end of stop lamp switch and ASCD cancel switch.		0.74 - 1.96 mm (0.0291 - 0.0772 in)
A	Pedal play		3 - 11 mm (0.12 - 0.43 in)

BRAKE PEDAL

ADJUSTMENT

1. Loosen stop lamp switch and ASCD cancel switch by rotating it counterclockwise by 45°.
2. Loosen lock nut (A) on input rod, then rotate input rod to set pedal to the specified height, and tighten lock nut (A).

CAUTION:

Check that the threaded end of input rod stays inside clevis.

Lock nut (A) :

15.7 - 21.6 N·m (1.6 - 2.2 kg-m, 12 - 15 in-lb)

3. With the pedal pulled and held by hand, press stop lamp switch and ASCD cancel switch until its threaded end contacts stopper rubber.
4. With the threaded end of stop lamp switch and ASCD cancel switch contacting stopper rubber, rotate the switch clockwise by 45° to secure.

CAUTION:

Make sure that the clearance (C) between stopper rubber and threaded end of stop lamp switch and ASCD cancel switch is within the standard.

5. Check the pedal play.

CAUTION:

Make sure that stop lamps go off when pedal is released.

6. Start engine to check brake pedal's depressed height.

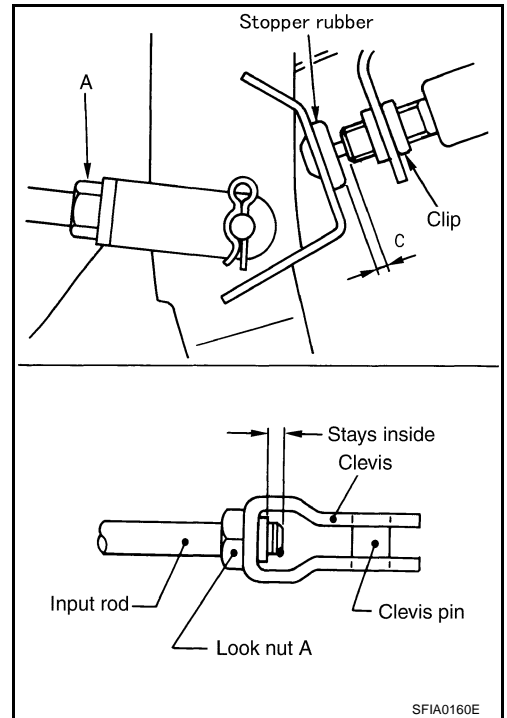

Removal and Installation COMPONENT PARTS LOCATION

AFS00007

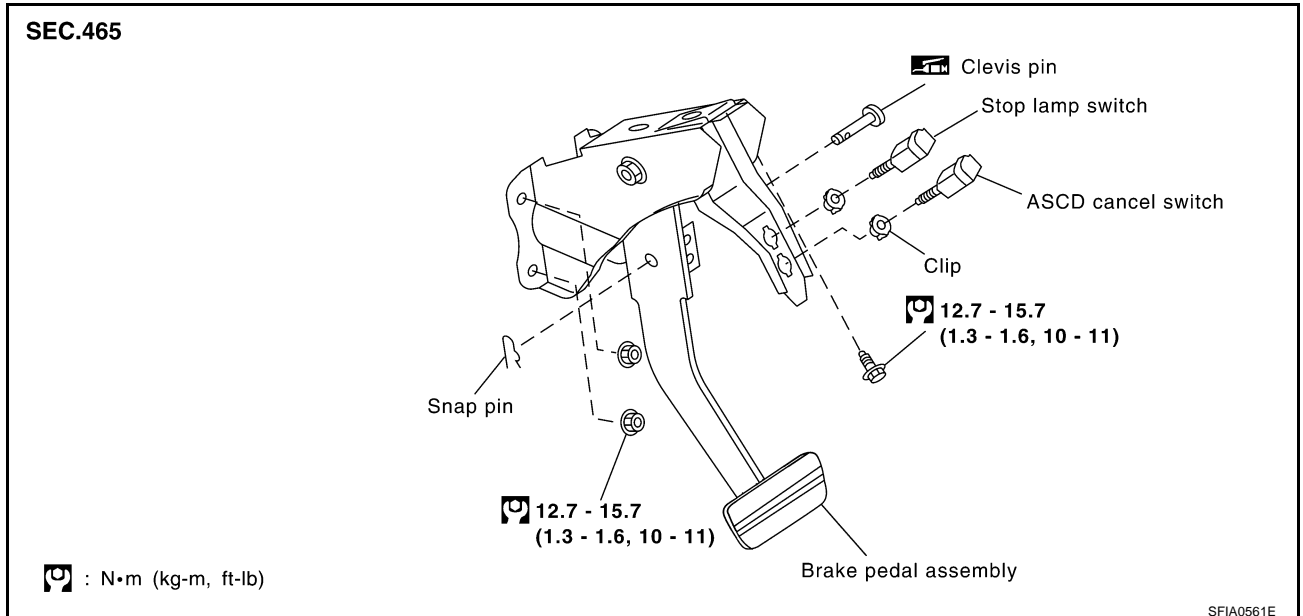

BRAKE PEDAL

REMOVAL

1. Remove the instrument lower driver panel. Refer to [IP-12, "INSTRUMENT LOWER DRIVER PANEL"](#).
2. Remove VDC/TCS/ABS control unit. Refer to [BRC-79, "VDC/TCS/ABS CONTROL UNIT"](#).
3. Remove stop lamp switch and ASCD cancel switch from pedal assembly.
4. Remove snap pin and clevis pin from brake booster clevis.
5. Remove mounting nuts and bolts from bracket, and remove pedal assembly from vehicle.

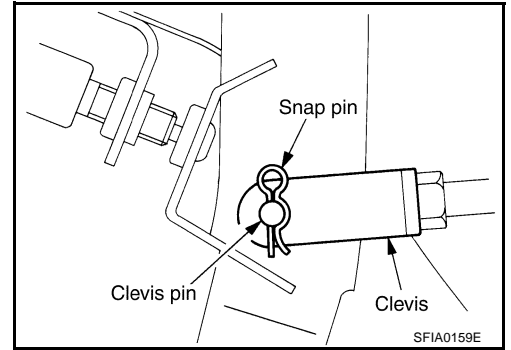

INSPECTION AFTER REMOVAL

- Check brake pedal for bend, damage, and cracks on the welded parts. Replace the applicable part if a failure is detected.
- Check clevis pin and resin stopper for damage and deformation. If a failure is detected, replace clevis pin.

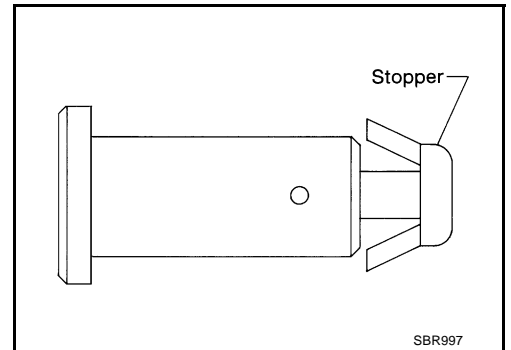

INSTALLATION

Paying attention to the following items, install in the reverse order of removal.

- After installing brake pedal assembly to vehicle, adjust brake pedal. Refer to [BR-7, "ADJUSTMENT"](#).

BRAKE FLUID

BRAKE FLUID

PFP:KN100

Checking Brake Fluid Level

AFS00008

- Check fluid level in reservoir tank. It should be between Max and Min lines on reservoir tank.
- If fluid level is extremely low, check brake system for leaks.
- Release parking brake lever or pedal, and then see if brake warning lamp goes off. If not, check brake system for leaks.

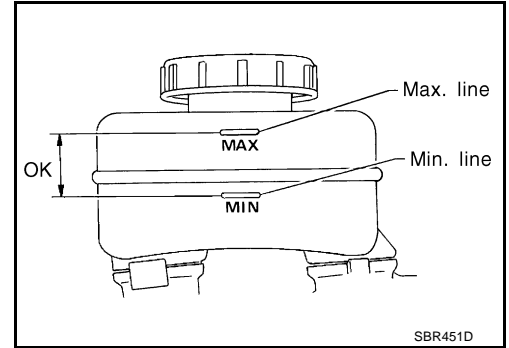

Checking Brake Line

AFS00009

CAUTION:

If leakage occurs around joints, retighten or, if necessary, replace damaged parts.

1. Check brake line (tubes and hoses) for cracks, deterioration or other damage. Replace any damaged parts.
2. Check for oil leakage by fully depressing brake pedal while engine is running.

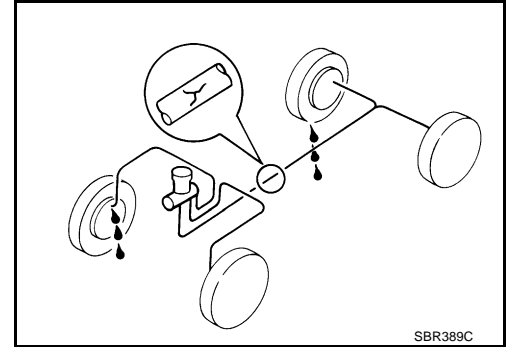

Drain and Refill

AFS001GB

CAUTION:

- Refill with new brake fluid "DOT3".
 - Never reuse drained brake fluid.
 - Do not let brake fluid come in contact with painted surfaces on the body. This might damage the paint, so if it does come in contact, immediately wipe area and wash off with water.
1. Turn ignition switch OFF and remove battery negative terminal.
 2. Connect a vinyl tube to bleed valve.
 3. Depress brake pedal, loosen bleed valve, and gradually remove brake fluid.

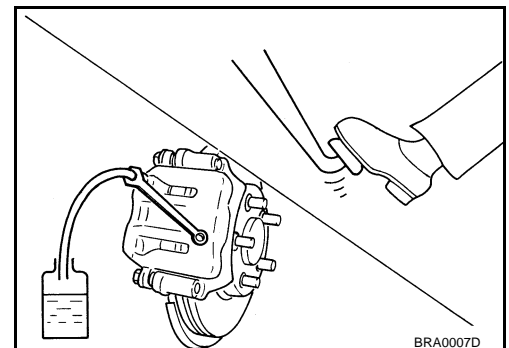

BRAKE FLUID

4. Make sure there is no foreign material in the reservoir tank, and refill with new brake fluid.
5. Rest foot on brake pedal. Loosen bleed valve. Slowly depress pedal until it stops. Tighten bleed valve. Release brake pedal. Repeat this process a few times, then pause to add new brake fluid to master cylinder. Continue until new brake fluid flows out. Bleed Air. Refer to [BR-10. "Bleeding Brake System"](#) .

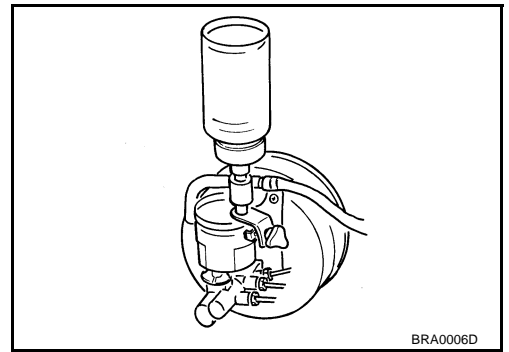

Bleeding Brake System

CAUTION:

- Carefully monitor brake fluid level at master cylinder during bleeding operation.
- Fill reservoir with new brake fluid "DOT 3". Make sure it is full at all times while bleeding air out of system.
- Place a container under master cylinder to avoid spillage of brake fluid.
- For models with ABS, turn ignition switch OFF and disconnect VDC actuator connectors or battery negative terminal.

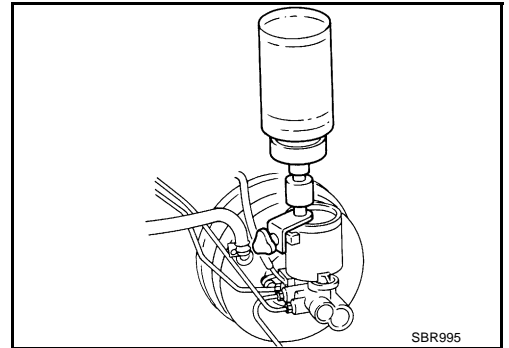

- Bleed air in the following order. Right rear brake → Left front brake → Left rear brake → Right front brake
1. Connect a transparent vinyl tube to bleed valve.
 2. Fully depress brake pedal several times.
 3. With brake pedal depressed, open bleed valve to release air.
 4. Close bleed valve.
 5. Release brake pedal slowly.
 6. Repeat steps 2, through 5, until clear brake fluid comes out of bleed valve.

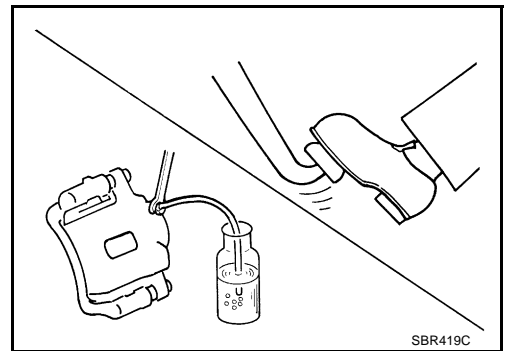

BRAKE PIPING AND HOSE

BRAKE PIPING AND HOSE

PFP:46210

Hydraulic Circuit

AFS0000B

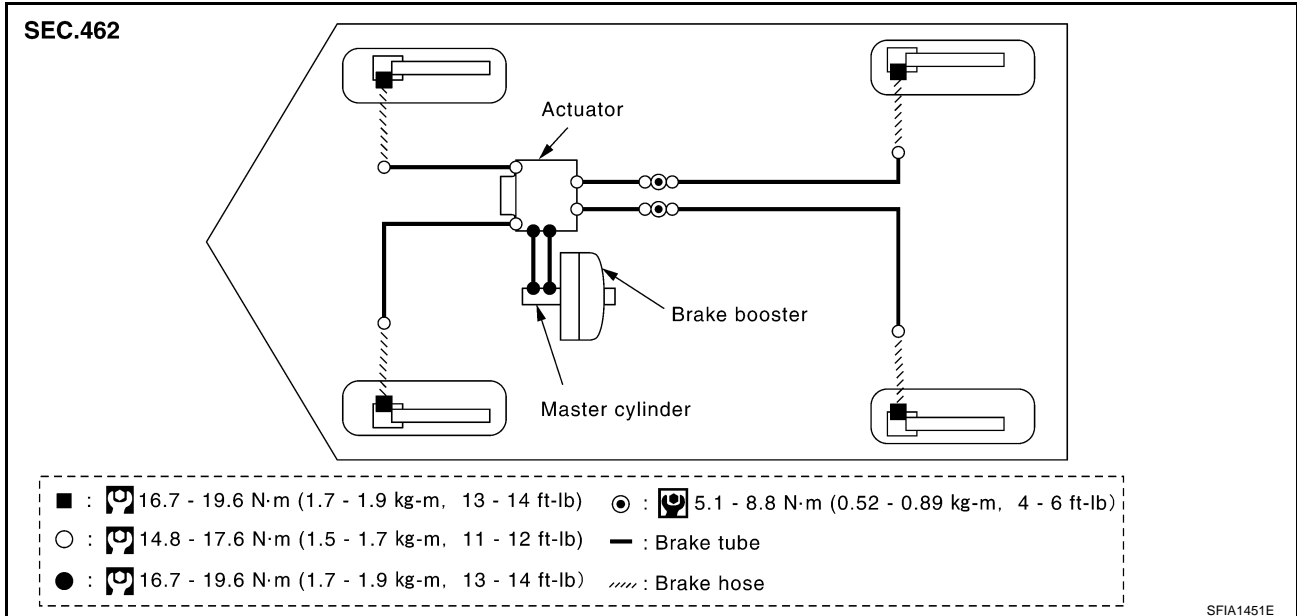

CAUTION:

- When installing, check for twist and fracture.
- Make sure that there is no interference with other parts when turning the steering clockwise or counterclockwise.
- Brake piping is an important safety part. If a brake fluid leak is detected, always disassemble the parts. Replace the applicable part with a new one.

Front Brake Piping and Hose

AFS0000C

REMOVAL

1. Connect a vinyl tube to air bleeder.
2. Drain brake fluid gradually from air bleeder of each wheel while depressing brake pedal.
3. Cover the brake line connection to prevent foreign material such as dust or dirt from entering into the connection.
4. Using a flare nut wrench, remove brake tube from brake hose. Remove union bolt, and remove brake hose from caliper assembly.
5. Remove lock plate.
6. Remove mounting nuts, and remove brake hose from vehicle.

INSTALLATION

1. Install brake hose by aligning with the protrusion on the caliper assembly, and tighten union bolts to the specified torque.

CAUTION:

- Do not reuse copper washer.
 - Refill with new brake fluid "DOT3".
 - Never reuse drained brake fluid.
2. Install brake hose to brake tube on vehicle, and temporarily tighten flare nut by hand until it stops to install bracket. Fix it with lock plate, and tighten it to the specified torque with flare nut wrench.
 3. Install brake hose to vehicle, and tighten mounting nuts to the specified torque.
 4. After the work, bleed air. Refer to [BR-10, "Bleeding Brake System"](#).

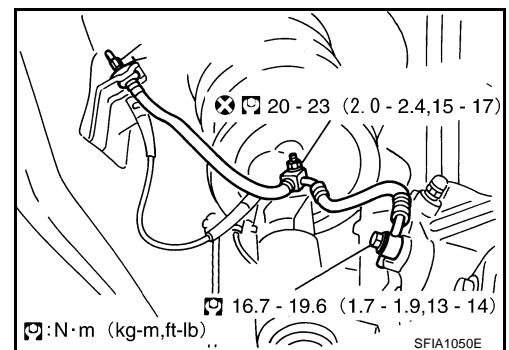

BRAKE PIPING AND HOSE

Rear Brake Piping and Hose REMOVAL

AFS0000D

1. Connect a vinyl tube to air bleeder.
2. Drain brake fluid gradually from air bleeder of each wheel while depressing brake pedal.
3. Cover the brake line connection to prevent foreign material such as dust or dirt from entering into the connection.
4. Using a flare nut wrench, remove brake tube from brake hose.
5. Remove union bolts, and then remove brake hose from caliper assembly.
6. Remove lock plate, and remove brake hose from vehicle.

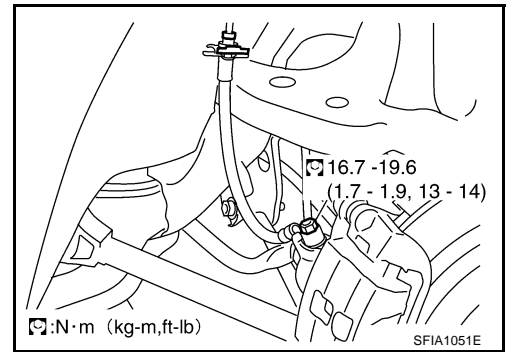

INSTALLATION

1. Install brake hose by aligning with the protrusion on the caliper assembly, and tighten union bolts to the specified torque.

CAUTION:

- Do not reuse copper washer.
 - Refill with new brake fluid "DOT3".
 - Never reuse drained brake fluid.
2. Install brake hose to brake tube on the vehicle, and temporarily tighten flare nut by hand until it stops to install bracket. Fix it with lock plate, and tighten it to the specified torque with flare nut wrench.
 3. After the work, bleed air. Refer to [BR-10, "Bleeding Brake System"](#) .

Inspection After Installation

AFS0000E

CAUTION:

If leak is detected at the connections, retighten it or replace the damaged part if necessary.

1. Check brake hose, tube, and connections for fluid leaks, damage, twist, deformation, contact with other parts, and loose connections.
2. While depressing pedal under the force of 785 N (80 kg, 177 lb) with the engine running for approximately 5 seconds, check for fluid leak from each part.

BRAKE MASTER CYLINDER

BRAKE MASTER CYLINDER

PFP:46010

Components

AFS0011B

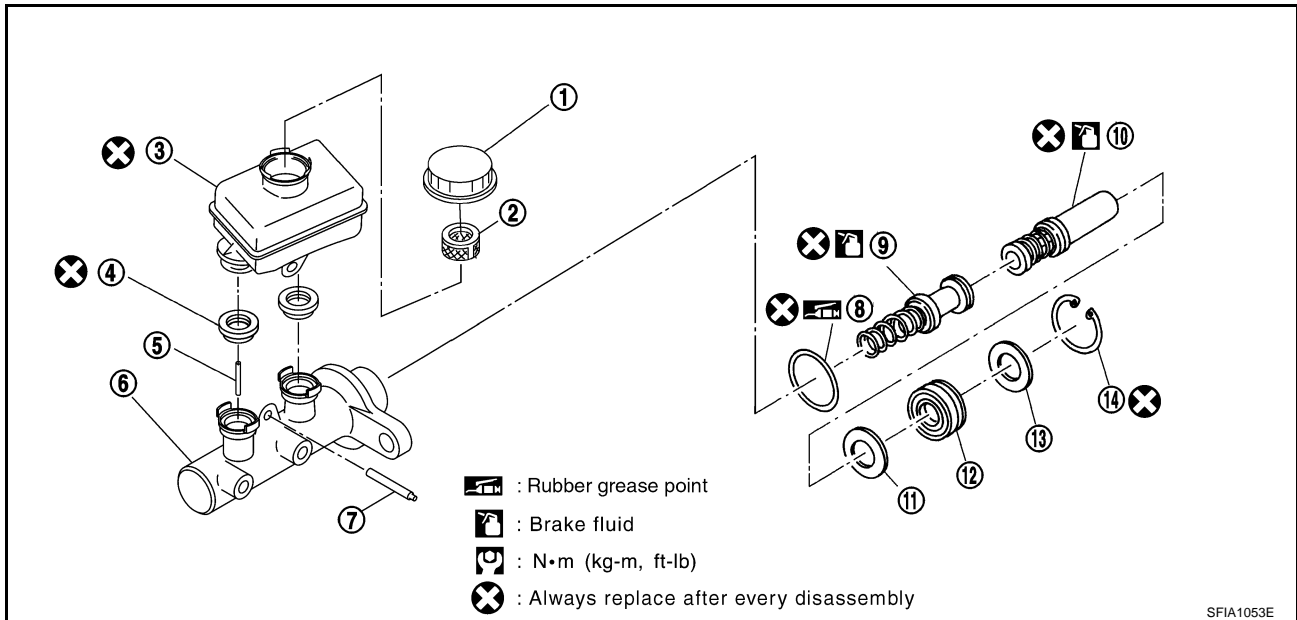

- | | | |
|--|------------------|---------------------|
| 1. Reservoir cap | 2. Oil filter | 3. Reservoir tank |
| 4. Seal | 5. Valve stopper | 6. Cylinder body |
| 7. Pin | 8. O-ring | 9. Secondary piston |
| 10. Primary piston | 11. Plate | 12. Guide assembly |
| 13. Plate (Not inserted in some vehicles.) | 14. Snap ring | |

Removal and Installation

REMOVAL

AFS001C7

1. Drain brake fluid. Refer to [BR-9, "Drain and Refill"](#).
2. Remove harness connectors for fluid level sensor.
3. Using a flare nut wrench, remove brake tube from master cylinder.
4. Remove mounting nuts, and remove master cylinder assembly from vehicle. Refer to [BR-18, "Removal and Installation"](#).

INSTALLATION

CAUTION:

- Refill with new brake fluid "DOT3".
- Never reuse drained brake fluid.

1. Temporarily tighten flare nuts on the brake tube to master cylinder by hand.
2. Install master cylinder to brake booster assembly, and tighten mounting nuts to the specified torque.

CAUTION:

- Do not damage and stain rod of primary piston.
- Do not reuse O-ring seal, and primary piston.
- Apply silicon grease for O-ring seal and primary piston.

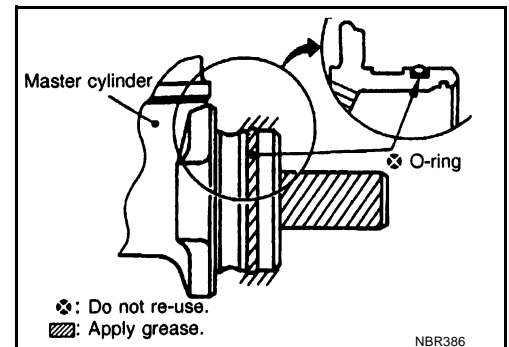

3. Using a flare nut torque wrench, tighten flare nut on the brake tube to the specified torque.

BRAKE MASTER CYLINDER

 : 16.7 - 19.6 N·m (1.7 - 1.9 kg-m, 13 - 14 ft-lb)

4. Refill new brake fluid and bleed air. Refer to [BR-10, "Bleeding Brake System"](#).

Disassembly and Assembly

DISASSEMBLY

AFS001C8

CAUTION:

Be careful not to damage rod of primary piston with covering cloths in acting.

1. Tighten flange of cylinder body in base in the figure.

CAUTION:

- Pay attention to the orientation of master cylinder body.
- Use copper plate or closes for fixing body in the vise.

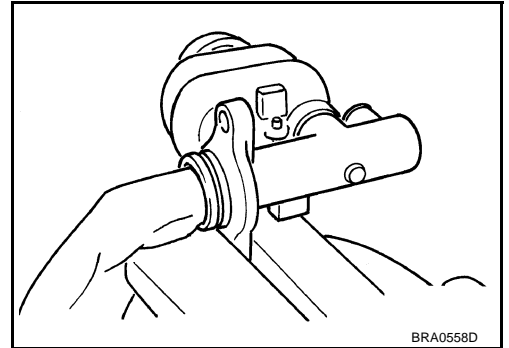

2. Using pin-punch (commercial service tool: dia approx. 4mm: 0.16in), remove pin from reservoir tank.
3. Remove master cylinder assembly from vise.
4. Remove reservoir tank and grommet from cylinder body.

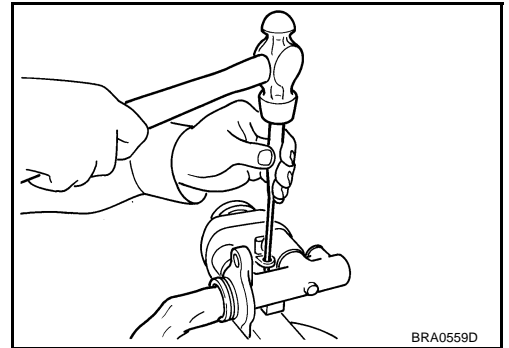

5. Push primary piston and remove stopper pin from secondary tank boss hole in the cylinder body.

CAUTION:

Be careful not to damage the inner wall of cylinder.

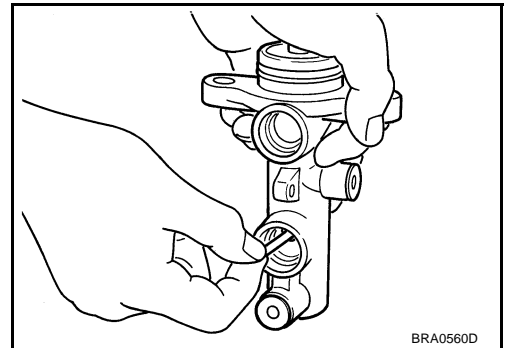

6. Remove snap ring in pushing primary piston.

CAUTION:

Be careful not to put out piston.

7. Holding rod of primary piston, remove primary piston assembly, plate and guide assembly with pulling straight to prevent cup from being caught by the inner wall of cylinder.
8. Remove plate and guide assembly from primary piston.

CAUTION:

Be careful not to damage rod from the inner wall of plate.

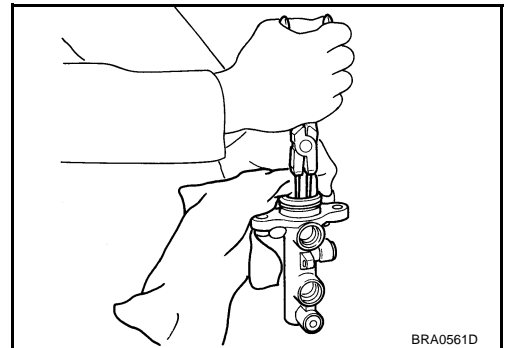

BRAKE MASTER CYLINDER

9. Tap flange using a soft block such as wood, and carefully pull secondary piston assembly straight out to prevent cylinder inner wall from being damaged.

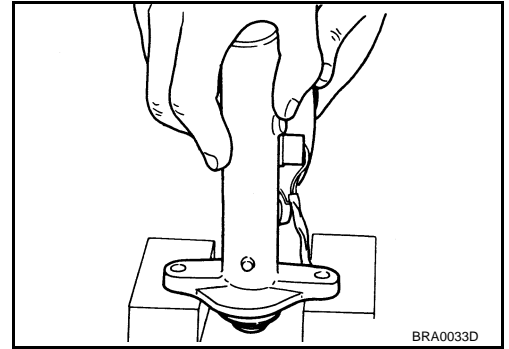

A
B
C
D
E

INSPECTION AFTER DISASSEMBLY

Inspect the next items.

Cylinder body

- Check the inner wall of cylinder for damage, wear, corrosion, and pin holes. Replace cylinder if a malfunction is detected.

ASSEMBLY

CAUTION:

- Never use mineral oils such as kerosene or gasoline during the cleaning and assembly processes.
- Make sure that there is no foreign material such as dirt and dust on the inner wall of cylinder, piston, and cup seal. Be careful not to damage parts with a service tool when assembling.
- Do not drop parts. Do not use any dropped parts.

1. Apply brake fluid to the inner wall of cylinder body and contact surface of piston assembly.
2. Insert secondary piston and primary piston assembly into cylinder body in this order.

CAUTION:

- Do not reuse primary and secondary piston assemblies.
 - Always replace inner kit as an assembly.
 - Pay attention to the orientation of piston cup, and insert straight to prevent cup from being caught by the inner wall of cylinder.
3. Align the slit in the center of secondary piston with the axial direction of valve stopper to assemble. Visually check secondary piston slit from valve stopper mounting hole, and install valve stopper.

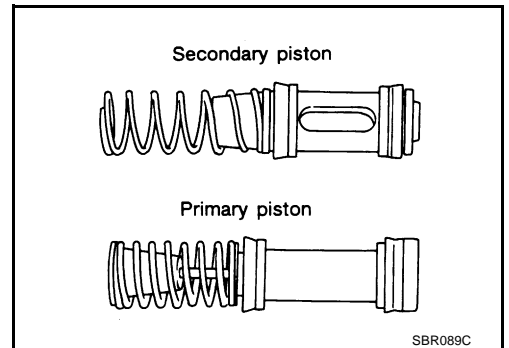

BR
G
H
I
J
K
L
M

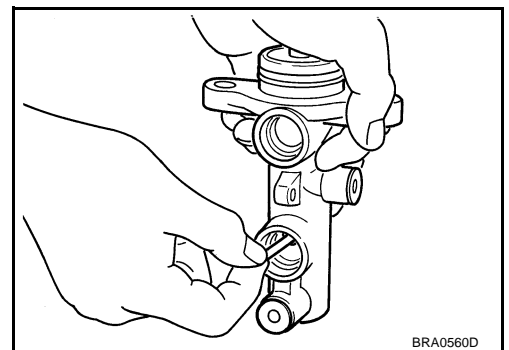

BRAKE MASTER CYLINDER

4. Insert plate and guide assembly into cylinder body.

CAUTION:

- There are two kinds of Guide assembly and plate. Shown in the figure and refer to [BR-13, "Components"](#).
- Be careful not to damage rod of primary piston.
- Pay attention to the orientation of guide assembly.
- Do not drop O-ring.

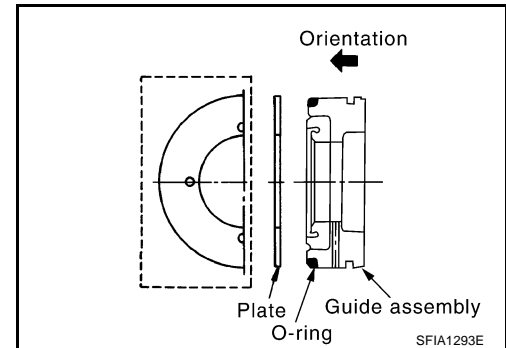
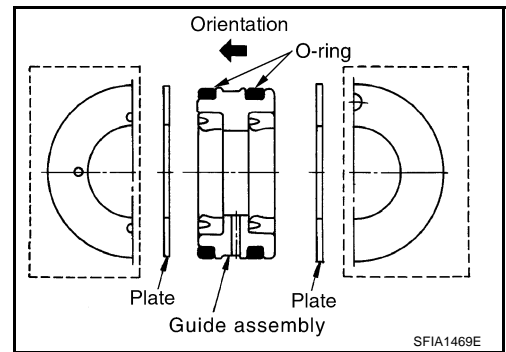

5. Be careful not to damage rod of primary piston with covering the close. Then insert snap ring to cylinder with pushing primary piston.

CAUTION:

- Be careful to check snap ring in the inner tip of cylinder body.
- Don not reuse snap ring.

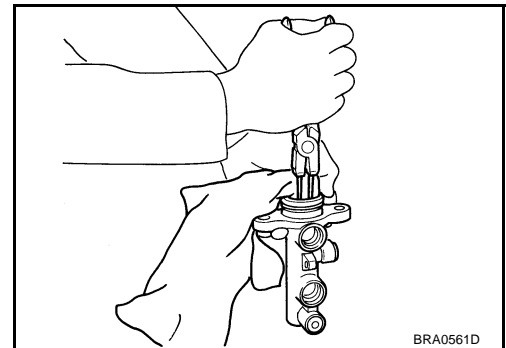

6. Tithing flange of cylinder body in the figure.

CAUTION:

- Using copper plate or closes to cover flange for fixing base.
- Pay attention to the orientation of cylinder body.

7. Apply brake fluid to a grommet, and press it into master cylinder to install.

CAUTION:

Do not reuse grommet.

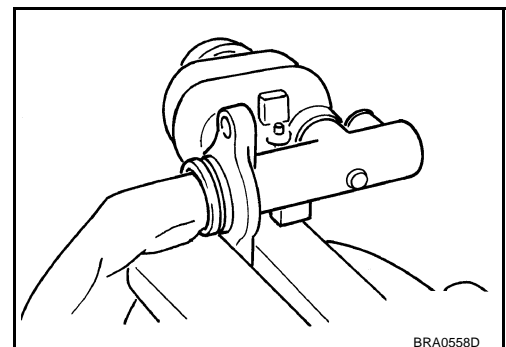

8. Install reservoir tank to master cylinder.

CAUTION:

Pay attention to the orientation of reservoir tank.

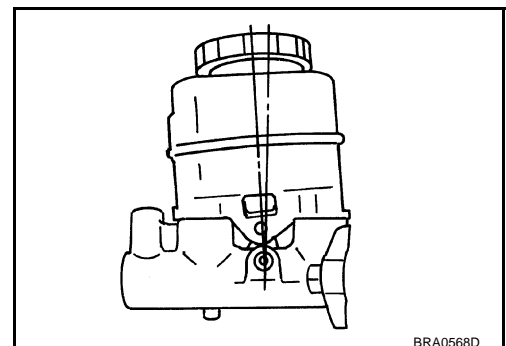

BRAKE MASTER CYLINDER

9. Set reservoir tank in the front direction to cylinder body. Press a new reservoir tank in cylinder body.

CAUTION:

- Pay attention to the orientation of piston cup, and insert straight to prevent cup from being caught by the inner wall of cylinder.
- Do not reuse reservoir tank.

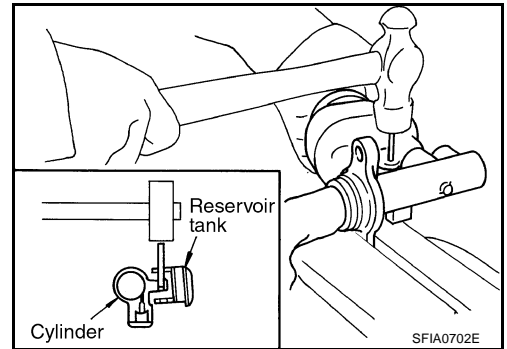

A
B
C
D

E

BR

G

H

I

J

K

L

M

BRAKE BOOSTER

PFP:47200

AFS0000G

BRAKE BOOSTER

On-Vehicle Service OPERATING CHECK

With the engine stopped, change the vacuum to the atmospheric pressure by depressing brake pedal several times. Then with brake pedal fully depressed, start engine and when the vacuum pressure reaches the standard, check that the clearance between brake pedal and floor panel decreases.

CAUTION:

Depressing pedal interval is approximately 5 seconds.

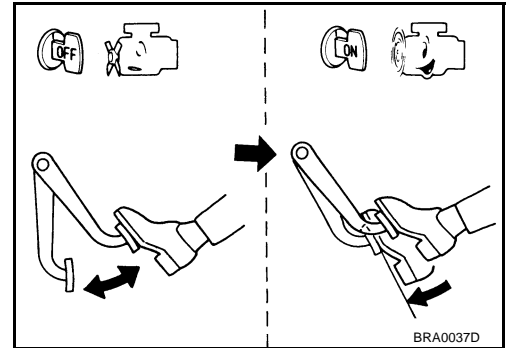

AIRTIGHT CHECK

- Run engine at idle for approximately 1 minute, and stop it after applying vacuum to booster. Depress brake pedal normally to change the vacuum to the atmospheric pressure. Check that distance between brake pedal and floor panel gradually increases.
- Depress brake pedal while engine is running, and stop engine with pedal depressed. The pedal stroke should not change after holding pedal down for 30 seconds.

CAUTION:

Depressing pedal interval is approximately 5 seconds.

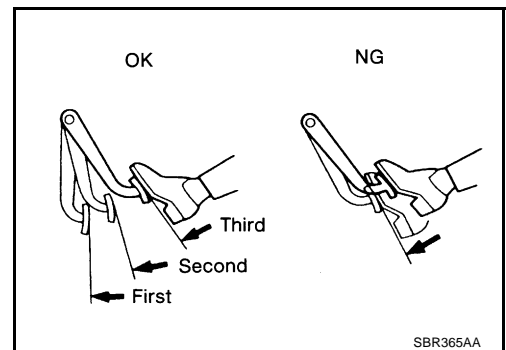

Removal and Installation

REMOVAL

CAUTION:

- Be careful not to deform or bend brake piping while removing and installing brake booster.
- Replace clevis pin if it is damaged.
- Be careful not to damage brake booster stud bolt threads. If brake booster is tilted or inclined during installation, dash panel may damage the threads.
- Be sure to install check valve in the correct orientation.

1. Remove vacuum hose from brake booster.
2. Remove master cylinder. Refer to [BR-13, "Removal and Installation"](#).
3. Remove snap pin and clevis pin on the clevis in the passenger compartment, and remove input rod from brake pedal. Refer to [BR-7, "COMPONENT PARTS LOCATION"](#).
4. Remove mounting nuts on pedal bracket.
5. Remove booster assembly from dash panel.

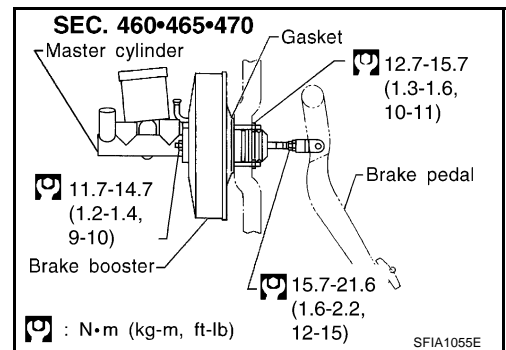

AFS0000H

BRAKE BOOSTER

INSPECTION AFTER REMOVAL

Output Rod Length Inspection

1. Using a handy vacuum pump, apply a vacuum of -66.7 kPa (-500 mmHg, 19.69 inHg) to brake booster.
2. Check output rod length.

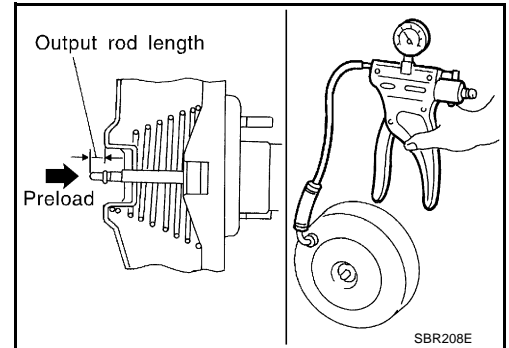

Standard dimension when vacuum -66.7 kPa (-500 mmHg, -19.69 inHg):

: -6.2 mm (-0.244 in)

INSTALLATION

1. Loosen lock nut to adjust input rod length so that the length B (shown in the figure) satisfies the specified value.

Length "B" : 125 mm (4.92 in)

2. After adjusting "B", temporarily tighten lock nut to install booster assembly to vehicle. At this time, make sure to install a gasket between booster assembly and dash panel.
3. Connect brake pedal with clevis of input rod.
4. Install pedal bracket mounting nuts and tighten them to the specified torque.
5. Install vacuum hose into brake booster. Refer to [BR-20, "Removal and Installation"](#).
6. Install master cylinder to booster assembly. Refer to [BR-13, "Removal and Installation"](#).
7. Adjust the height and play of brake pedal. Refer to [BR-7, "ADJUSTMENT"](#).
8. Tighten lock nut of input rod to the specified torque.
9. Bleed air. Refer to [BR-10, "Bleeding Brake System"](#).

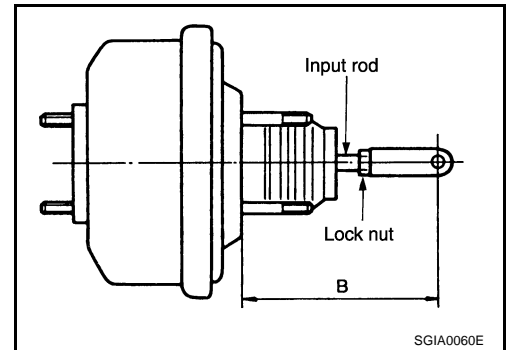

VACUUM LINES

VACUUM LINES

PFP:41920

Removal and Installation

AFS0007E

CAUTION:

- Because vacuum hose contains a check valve, it must be installed in the correct orientation. Refer to the stamp or label to confirm correct installation. Brake booster will not operate normally if hose is installed in the wrong direction.
- Insert vacuum hose for at least 24 mm (0.94 in).
- Never use lubricating oil during assembly.

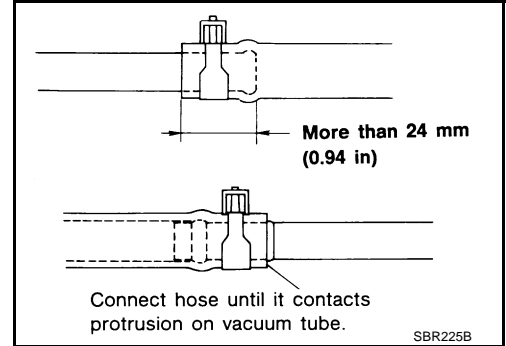

Inspection

VISUAL INSPECTION

Check for improper assembly, damage and aging.

CHECK VALVE INSPECTION

Airtightness Inspection

Use a hand-held vacuum pump to check.

When connected to booster side (1):

Vacuum decrease should be within 1.3 kPa (10 mmHg, 0.39 inHg) for 15 seconds under a vacuum of -66.7 kPa (-500 mmHg, -19.69 inHg)

When connected to engine side (2):

No vacuum will be applied

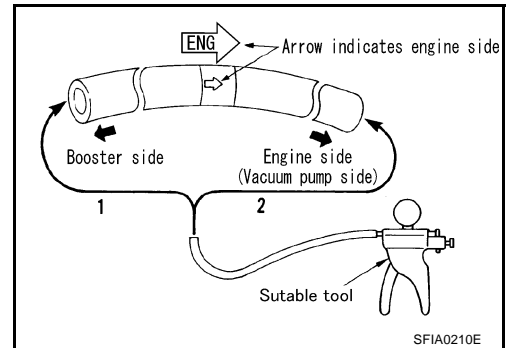

FRONT DISC BRAKE

FRONT DISC BRAKE

PPF:41000

Components

AFS00001

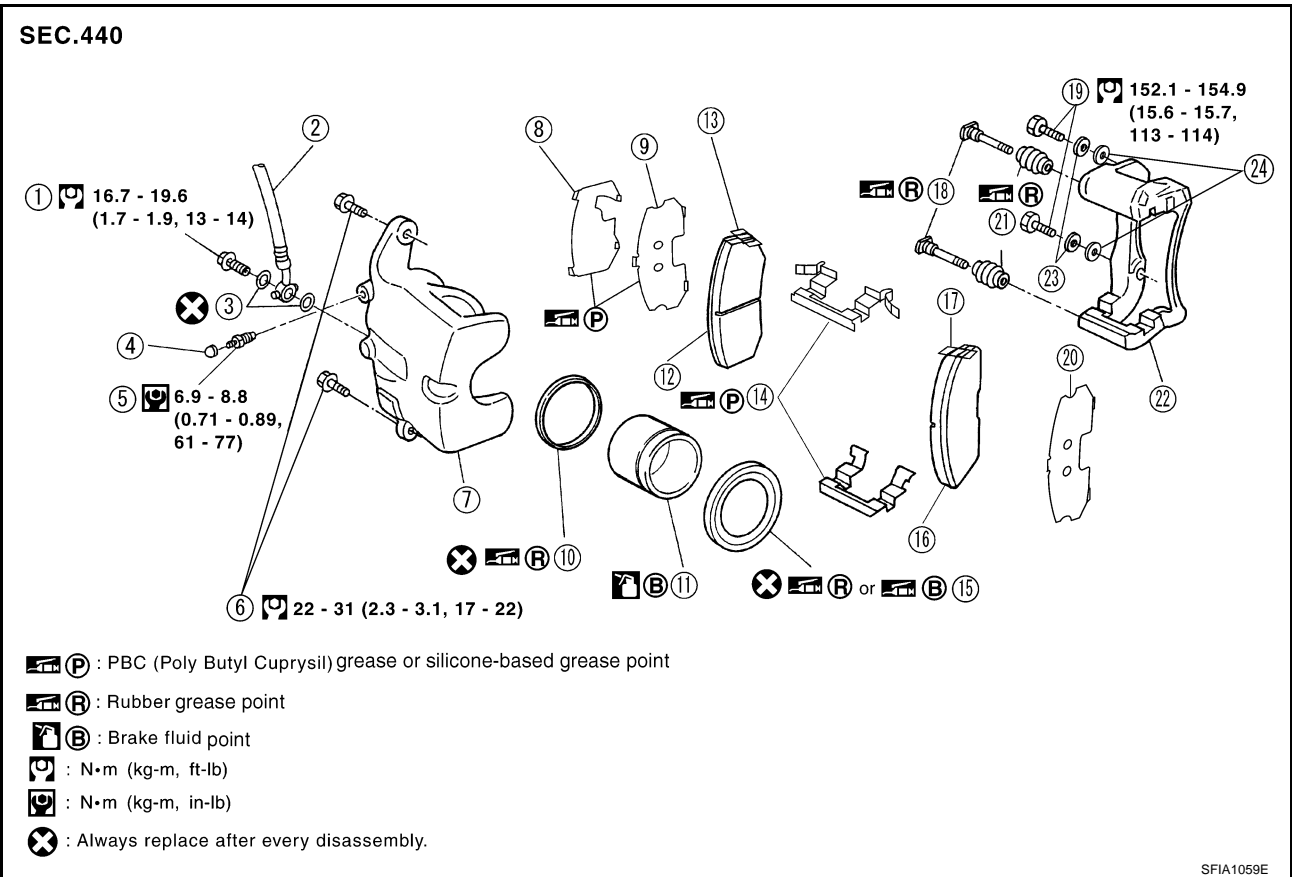

- | | | |
|-------------------------|---------------------|---|
| 1. Union bolt | 2. Brake hose | 3. Copper washer |
| 4. Cap | 5. Bleed valve | 6. Sliding pin bolt |
| 7. Cylinder body | 8. Inner shim cover | 9. Inner shim |
| 10. Piston seal | 11. Piston | 12. Inner pad |
| 13. Pad wear sensor | 14. Pad retainer | 15. Piston boot |
| 16. Outer pad | 17. Pad wear sensor | 18. Sliding pin bolt |
| 19. Torque member bolts | 20. Outer shim | 21. Slide pin boot |
| 22. Torque member | 23. Washer | 24. Decrement shim (Not inserted in some vehicles.) |

CAUTION:

- Clean dust on the caliper and brake pad with a vacuum dust collector. Do not blow with compressed air.
- While removing cylinder body, never depress brake pedal because piston will pop out.
- It is not necessary to remove mounting bolts on the torque member and brake hose except for disassembly or replacement of caliper assembly. In this case, hang cylinder body with a wire so that brake hose is not under tension.
- Do not damage piston boot.
- Always replace shims and shim covers as a set when replacing brake pads.
- Keep brake fluid clean of rotor.

FRONT DISC BRAKE

Inspection

PAD THICKNESS

AFS0000J

- Remove wheel with vehicle lifted to check pad thickness from check hole on the cylinder body. If necessary, use a scale to check.

Standard thickness : 11.0 mm (0.433 in)

Repair limit thickness : 2.0 mm (0.079 in)

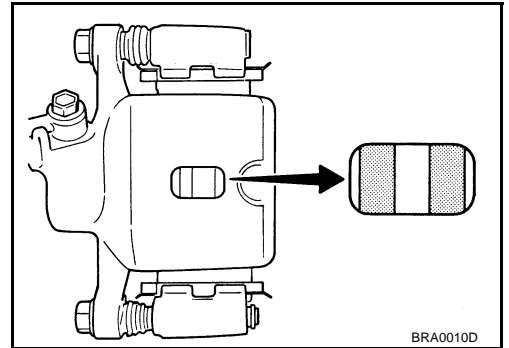

Pad Replacement REMOVAL

AFS0000K

WARNING:

Clean brake pads with a vacuum dust collector to minimize the hazard of airborne particles or other materials.

CAUTION:

- When cylinder body is open, do not depress brake pedal because piston will pop out.
- Be careful not to damage piston boot or get oil on rotor always replace shims in replacing pads.
- If shims are rusted or show peeling of rubber coat, replace them with new shims.
- It is not necessary to remove connecting bolt except for disassembly or replacement of caliper assembly. In this case, suspend cylinder body with wire so as not to stretch brake hose.
- Carefully monitor brake fluid level because brake fluid will return to reservoir when pushing back piston.
- Burnish the brake contact surfaces after refinishing or replacing rotors, after replacing pads, or if a soft pedal occurs at very low mileage. Refer to [BR-26, "Brake Burnishing Procedure"](#).

1. Remove master cylinder reservoir cap.
2. Remove tire.
3. Remove lower sliding pin bolt.

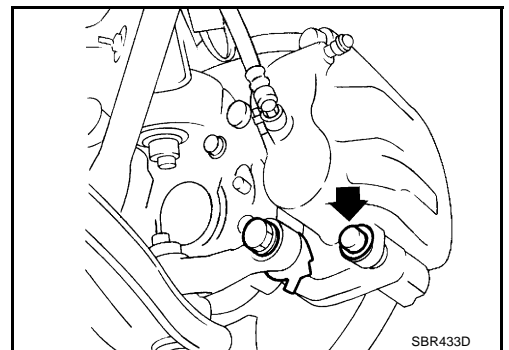

4. Hang cylinder body with a wire, and remove pads, pad retainers, shims from torque member.

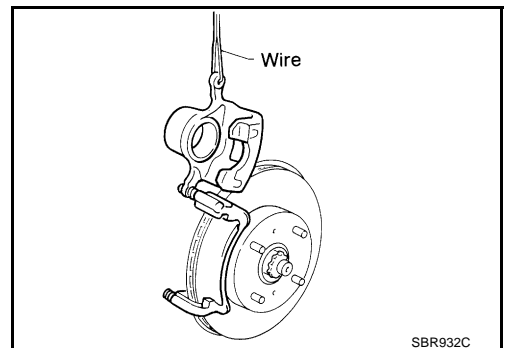

FRONT DISC BRAKE

CAUTION:

- When removing pad retainer from torque member, lift pad retainer in the direction shown by the arrow (shown in the figure) so as not to deform it.
- Do not damage piston boot.
- Keep brake fluid clean of rotor.

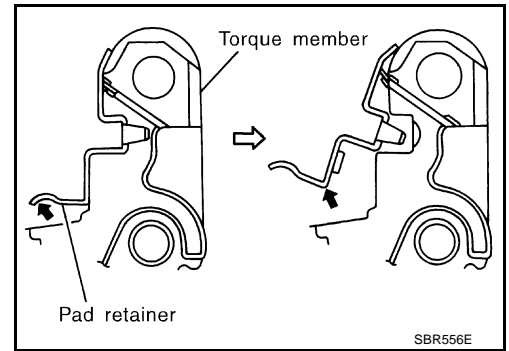

A
B
C
D

INSTALLATION

1. Apply brake grease on back of pad and both sides of shim, install inner shim and inner shim cover to inner pad, outer shim to outer pad.
2. Apply brake grease on the pad retainer pad retainer pad contact surface. Install pad retainers, pads and return springs to torque member.
3. Connect cylinder body to torque member.

CAUTION:

When replacing pads with new ones, press piston in until pads can be installed. Carefully monitor brake master cylinder reservoir fluid level. Brake fluid will return, raising master cylinder reservoir tank fluid level.

4. Insert lower sliding pin bolt and tighten to the specified torque.
5. Check brake for drag.
6. Install tire.

BR

G

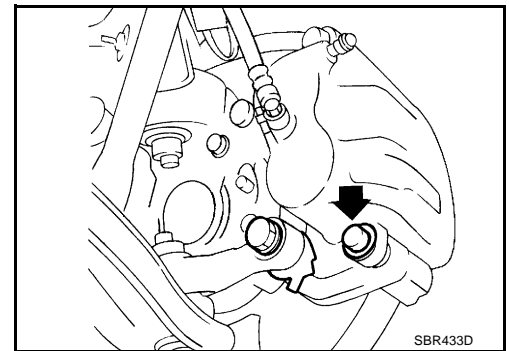

H

I

J

Caliper Removal and Installation

REMOVAL

1. Remove tire.
2. Connect a vinyl tube to air bleeder.
3. Drain brake fluid gradually from bleed valve while depressing brake pedal.
4. Remove union bolts, and then remove brake hose from caliper assembly.
5. Remove mounting bolts from torque member, and remove caliper assembly from vehicle with power tool.
6. Remove disc rotor.

AFS000L

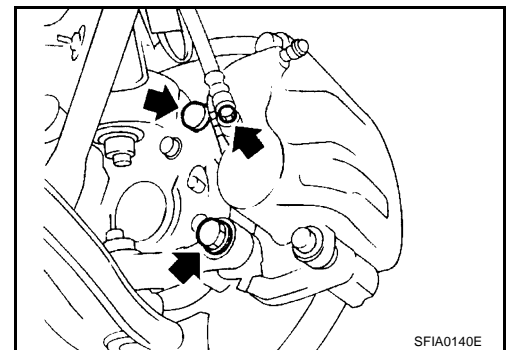

K

L

M

INSTALLATION

1. Install disc rotor.
2. Install caliper assembly to vehicle, and tighten mounting bolts to the specified torque.

CAUTION:

Before installing torque member to vehicle, wipe oil and grease on the washer seats on the knuckle spindle and mounting surface of torque member.

3. Install brake hose by aligning with the protrusions on the caliper assembly, and tighten union bolts to the specified torque.

FRONT DISC BRAKE

CAUTION:

- Do not reuse copper washer for union bolts.
- Assemble brake hose securely to the protrusions on caliper assembly.

4. After installing caliper assembly, refill with new brake fluid and bleed air. Refer to [BR-10, "Bleeding Brake System"](#).
5. Install tire.

Caliper Disassembly and Assembly DISASSEMBLY

AFS0000M

1. Remove caliper assembly from vehicle.
2. Remove sliding pin bolts from cylinder body, and remove pad, shim, shim cover and pad retainer from torque member.

CAUTION:

When removing pad retainer from torque member, lift pad retainer in the direction shown by the arrow (shown in the figure) so as not to deform it.

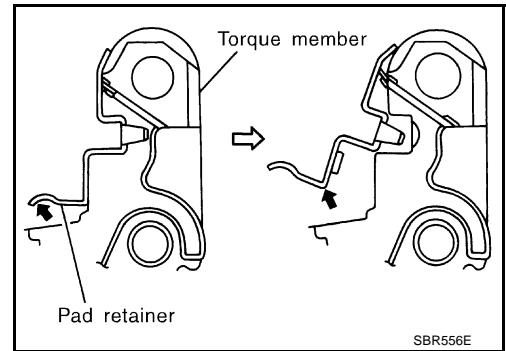

3. Remove sliding pins and sliding pin boots from torque member.
4. Place a wooden block as shown at the right, and blow air from union bolt mounting hole to remove pistons and piston boots.
5. Remove piston seal with a suitable tool.

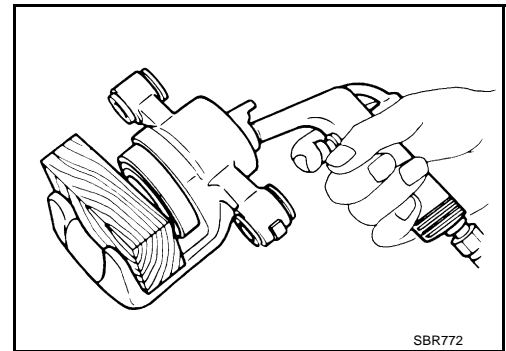

INSPECTION AFTER DISASSEMBLY

Cylinder Body

CAUTION:

Use new brake fluid to clean. Never use mineral oils such as gasoline or kerosene.

- Check the inner wall of cylinder for corrosion, wear, and damage. If a failure is detected, replace cylinder body.
- Minor flaws caused by corrosion or a foreign material can be removed by polishing the surface with a fine sandpaper. Replace cylinder body, if necessary.

Torque Member

Check for wear, cracks, and damage. If a malfunction is detected, replace applicable part.

Piston

CAUTION:

The piston sliding surface is plated. Do not polish with sandpaper.

Check the piston surface for corrosion, wear, and damage. If a malfunction is detected, replace applicable part.

Sliding Pin, Sliding Pin Bolt and Pin Boot

Check sliding pin, sliding pin bolt and sliding pin boot for wear, damage, and cracks. If a malfunction is detected, replace applicable part.

DISC ROTOR INSPECTION

Visual Inspection

Check the surface of disc rotor for uneven wear, cracks, and serious damage. If a malfunction is detected, replace applicable part.

FRONT DISC BRAKE

Runout Inspection

1. Using wheel nuts, fix disc rotor to wheels hub. (2 or more positions)
2. Using a dial indicator, check the runout.

Measurement point:

At a point 10 mm (0.39 in) from the outer edge of disc.

Maximum runout:

0.07 mm (0.0028 in) or less

CAUTION:

Before measuring, make sure that the axle endplay is 0.05 mm (0.002in) or less.

3. If the runout is outside the limit, find the minimum runout point by shifting the mounting positions of disc rotor and wheel hub by one hole.
4. If the runout is still out of specification, turn rotor with on-car brake lathe ("MAD DL-8700", "AMMCO 700 and 705" or equivalent).

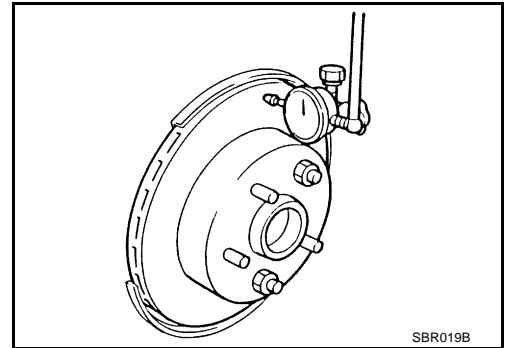

Thickness Inspection

1. Using a micrometer, check the thickness of disc rotor. If the thickness is outside the standard, replace disc rotor.

Standard thickness :24.0 mm (0.945 in)

Wear limit :22.0 mm (0.866 in)

Maximum uneven wear (measured at 8 positions):
0.015 mm (0,0006 in) or less

2. If the runout is still out of specification, turn rotor with on-car brake lathe ("MAD, DL-8700", "AMMCO 700 and 705" or equivalent).

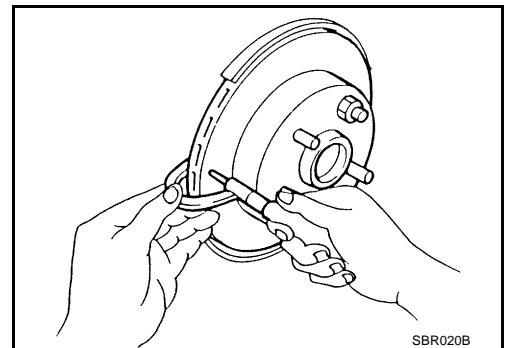

ASSEMBLY

CAUTION:

When assembling, do not use NISSAN rubber grease (KRE00 00010, KRE00 00010 01).

1. Apply rubber grease to new piston seals, and install them to groove on cylinder body.

CAUTION:

Do not reuse piston seal.

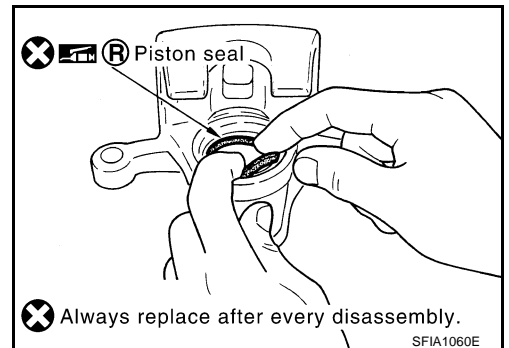

2. Apply rubber grease to piston boots. Cover piston end with piston boot, and install cylinder-side lip on the piston boot properly into the groove on the cylinder body.

CAUTION:

Do not reuse piston boot.

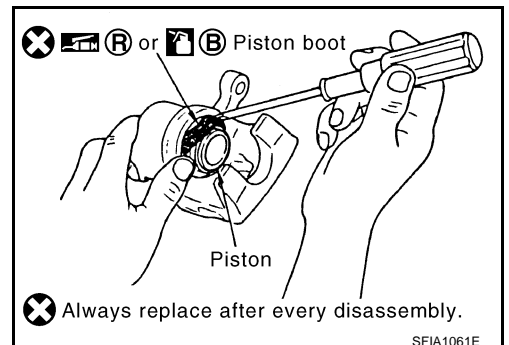

FRONT DISC BRAKE

3. Apply brake fluid "DOT3" to piston, and press piston into cylinder body by hand to assemble piston-side lip on the piston boot properly into the groove on the piston.

CAUTION:

Press the piston evenly and change the pressing point to prevent the inner wall of cylinder from being rubbed.

4. Install sliding pins and sliding pin boots to torque member.

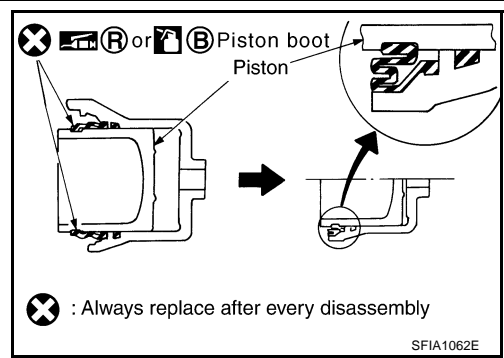

5. Install torque member to knuckle spindle and tighten torque member fixing bolts to the specified torque.

CAUTION:

Before installing the torque member to vehicle, wipe oil and grease on the washer seats on the knuckle spindle and mounting surface of torque member.

6. Install pad retainers to torque member.
7. After assembling shims and shim covers to pad, install it to torque member.

CAUTION:

Inner pad and outer pad have the pad-return mechanism on the upper side of pad retainer. When installing pad, be sure to install pad return lever to pad wear sensor securely shown to the right.

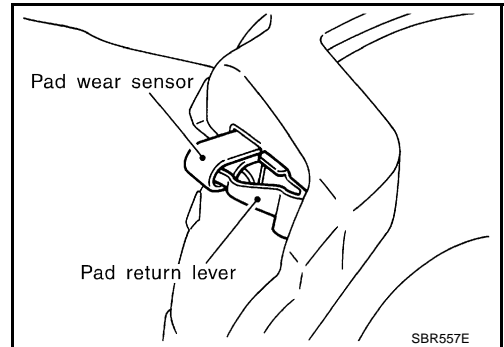

8. Install cylinder body, and tighten sliding pin bolt to the specified torque.
9. Install brake hose to cylinder body and tighten union bolt to the specified torque.

CAUTION:

- Assemble brake hose securely to the protrusions on the cylinder body.
- Do not reuse copper washer for union bolts.

Brake Burnishing Procedure

AFS0000N

Burnish the brake contact surfaces according to the following procedure after refinishing or replacing rotors, after replacing pads, or if a soft pedal occurs at very low mileage.

CAUTION:

Only perform this procedure under safe road and traffic conditions. Use extreme caution.

1. Drive vehicle on a straight smooth road at 50 km/h (31 MPH).
2. Use medium brake pedal/foot effort to bring vehicle to a complete stop from 50 km/h (31 MPH). Adjust brake pedal/foot pressure such that vehicle stopping time equals 3 to 5 seconds.
3. To cool the brake system, drive vehicle at 50 km/h (31 MPH) for 1 minute without stopping.
4. Repeat steps 1 to 3, 10 times or more to complete the burnishing procedure.

REAR DISC BRAKE

Inspection PAD THICKNESS

AFS0000P

- Remove wheel with vehicle lifted to check the pad thickness from the check hole on the cylinder body. If necessary, use a scale to check.

Standard thickness : 8.5 mm (0.335 in)

Repair limit thickness : 2.0 mm (0.079 in)

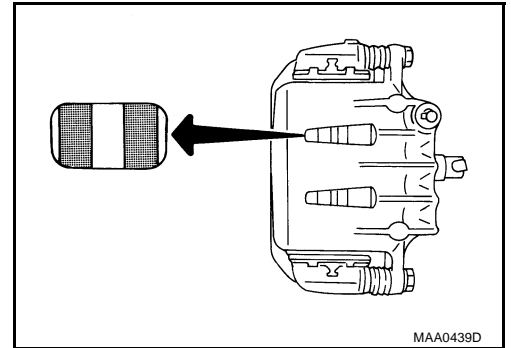

Pad Replacement REMOVAL

AFS0000Q

WARNING:

Clean brake pads with a vacuum dust collector to minimize the hazard of airborne particles or other materials.

CAUTION:

- While cylinder body is open, do not depress brake pedal, otherwise piston will pop out.
 - Be careful not to damage piston boot or get oil on rotor, Always replace shims when replacing pads.
 - If shims are rusted or show peeling of rubber coat, replace them with new shims.
 - It is not necessary to remove connecting bolt except for disassembly or replacement of caliper assembly. In this case, suspend cylinder body with wire so as not to stretch brake hose.
 - Carefully monitor brake fluid level because brake fluid will return to reservoir when pushing back piston.
 - Burnish the brake contact surfaces after refinishing or replacing drums or rotor, after replacing pads or linings, or if a soft pedal occurs at very low mileage. Refer to [BR-26, "Brake Burnishing Procedure"](#).
1. Remove master cylinder reservoir cap.
 2. Remove tire.
 3. Remove lower sliding pin bolt.

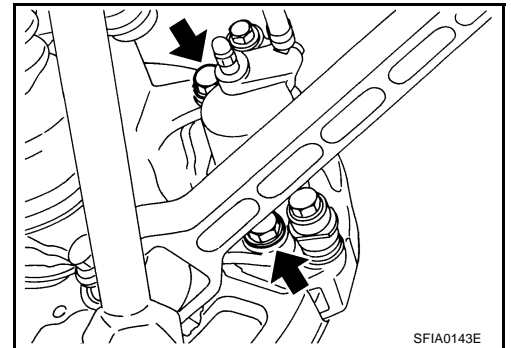

REAR DISC BRAKE

4. Hang cylinder body with a wire, and remove pads, pad retainers, shims from torque member.

CAUTION:

- Do not damage piston boot.
- Keep brake fluid clean of rotor.

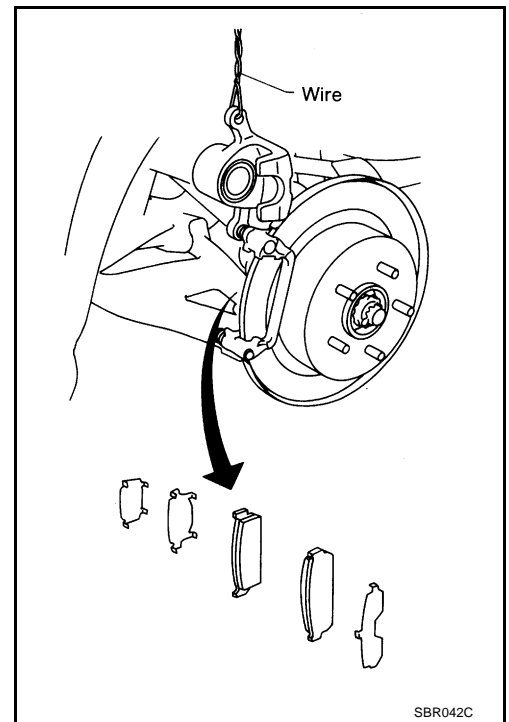

A
B
C
D
E
BR
G

INSTALLATION

1. Apply brake grease to the back of pad and both sides of shim, and install inner shim and inner shim cover to inner pad, and outer shim and outer shim cover to pad.
2. Apply disc brake grease to the pad contact surface on the pad retainer, and install pad retainers and pads to torque member.
3. Install cylinder body to torque member.

CAUTION:

When replacing pads with new ones, press in the piston until pads can be installed. In this case, carefully monitor the brake fluid level in the reservoir tank because brake fluid will return to reservoir tank of master cylinder.

4. Insert lower sliding pin bolt to tighten to the specified torque. Refer to [BR-27, "Component"](#).
5. Check brake for drag.
6. Install tire.

Caliper Removal and Installation

REMOVAL

1. Connect a vinyl tube to bleed valve.
2. Drain brake fluid gradually from air bleeder while depressing brake pedal.
3. Remove union bolts, and then remove brake hose from caliper assembly.
4. Remove torque member fixing bolt from torque member, and remove caliper assembly from vehicle with power tool.
5. Remove disc rotor.

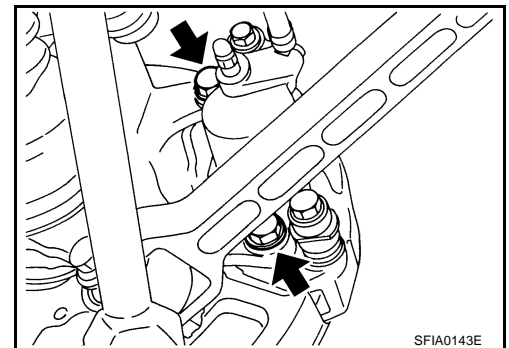

AFS0000R

L
M

INSTALLATION

1. Install disc rotor.
2. Install caliper assembly to vehicle, and tighten torque member fixing bolts to the specified torque. Refer to [BR-27, "Component"](#).

CAUTION:

Before installing caliper assembly to vehicle, wipe oil and grease on the washer seats on the axle assembly and mounting surface of caliper assembly.

REAR DISC BRAKE

3. Install brake hose to caliper assembly and tighten union bolts to the specified torque. Refer to [BR-27, "Component"](#).
CAUTION:
 - Do not reuse copper washer for union bolts.
 - Assemble brake hose securely to the protrusion on caliper assembly.
4. After installing caliper assembly, refill with new brake fluid and bleed air. Refer to [BR-10, "Bleeding Brake System"](#).
5. Install tire.

Caliper Disassembly and Assembly

DISASSEMBLY

AFS0000S

1. Remove caliper assembly from vehicle.
2. Remove sliding pin bolts and cylinder body from torque member. Then remove pads, shims, and shim covers from torque member, and remove pad retainers from cylinder body.
3. Remove sliding pin boot from torque member.
4. Using a flat-bladed screwdriver as shown in the figure, remove retaining ring from torque member.

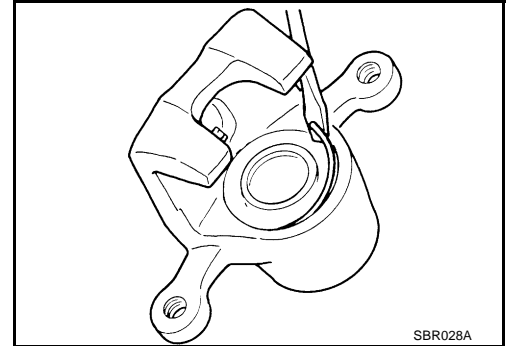

5. Place a wooden block as shown in the figure, and blow air from union bolt mounting hole to remove piston and piston boots.
6. Remove piston seal with a suitable tool.

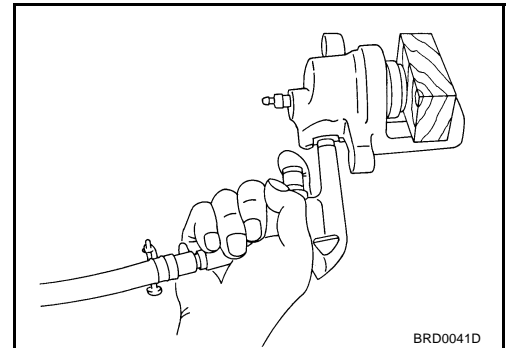

INSPECTION AFTER DISASSEMBLY

Cylinder Body

CAUTION:

Use new brake fluid to clean. Never use mineral oils such as gasoline or kerosene.

- Check the inner wall of cylinder for corrosion, wear, and damage. If a failure is detected, replace cylinder body.
- Minor flaws caused by corrosion or foreign material can be removed by polishing the surface with a fine sandpaper. Replace cylinder body, if necessary.

Torque Member

Check for wear, cracks, and damage. If a malfunction is detected, replace applicable part.

Piston

CAUTION:

The piston sliding surface is plated. Do not polish with sandpaper.

Check the piston surface for corrosion, wear, and damage. If a malfunction is detected, replace applicable part.

Sliding Pin Bolt and Sliding Pin Boot

Check sliding pin bolts and sliding pin boot for wear, damage, and cracks. If a malfunction is detected, replace applicable part.

REAR DISC BRAKE

DISC ROTOR INSPECTION

Visual Inspection

Check the surface of disc rotor for uneven wear, cracks, and serious damage. If a malfunction is detected, replace applicable part.

Runout Inspection

1. Using wheel nuts, fix disc rotor to wheels hub. (2 or more positions)
2. Using a dial indicator, check the runout.

Measurement point:

At a point 10 mm (0.39 in) from the outer edge of disc.

Maximum runout:

0.10 mm (0.0039 in) or less

CAUTION:

Before measuring, make sure that the axle endplay is 0.05 mm (0.002in) or less.

3. If the runout is outside the limit, find the minimum runout point by shifting the mounting positions of disc rotor and wheel hub by one hole.
4. If the runout is still out of specification, turn rotor with on-car brake lathe ("MAD DL-8700", "AMMCO 700 and 705" or equivalent).

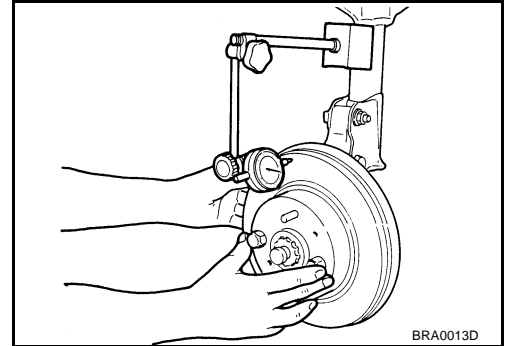

Thickness Inspection

Using a micrometer, check the thickness of disc rotor. If the thickness is outside the standard, replace disc rotor.

Standard thickness : 16.0 mm (0.630 in)

Wear limit : 14.0 mm (0.551 in)

Maximum uneven wear (measured at 8 positions):
0.015 mm (0.0006 in) or less

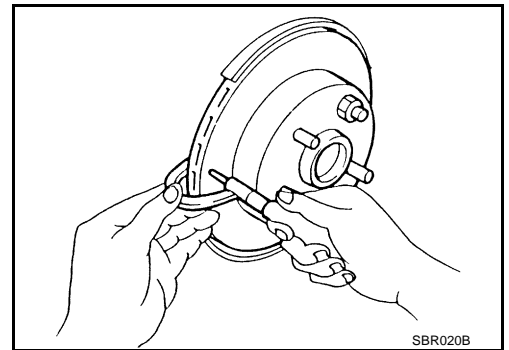

ASSEMBLY

CAUTION:

When assembling, do not use NISSAN rubber grease (KRE00 00010, KRE00 00010 01).

1. Apply rubber grease to new piston seals, and install them to groove on cylinder body.

CAUTION:

Do not reuse piston seal.

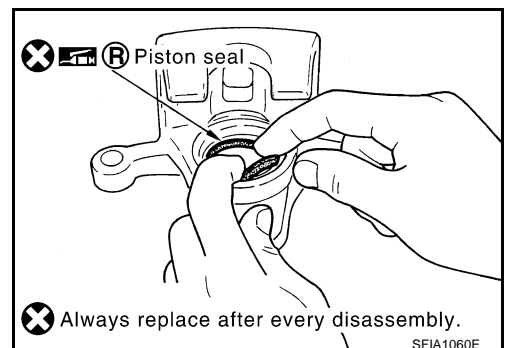

REAR DISC BRAKE

2. Apply brake fluid to piston boots. Cover piston end with piston boot, and install cylinder-side lip on the piston boots properly into the groove on the cylinder body.

CAUTION:

Do not reuse piston boot.

3. Press piston into cylinder body by hand to assemble piston-side lip on the piston boot properly into the groove on the piston.

CAUTION:

Press piston evenly and change the pressing point to prevent the inner wall of cylinder from being rubbed.

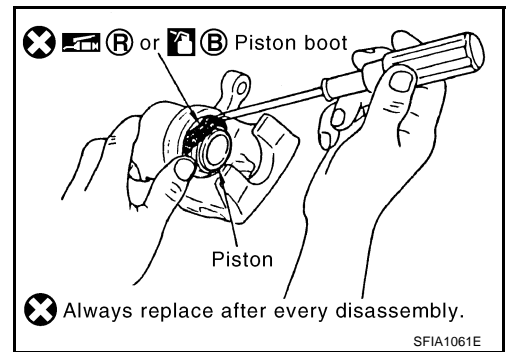

4. Fix piston boot with retaining ring.

CAUTION:

- **Make sure that boot is securely engaged in the groove on cylinder body.**

- **Do not reuse retaining ring.**

5. Install sliding pin bolts and sliding pin boots to torque member.
6. Install torque member to axle assembly, and tighten torque member fixing bolt to the specified torque.

CAUTION:

Before installing torque member to axle assembly, wipe oil and grease on the washer seats on the axle assembly and mounting surface of torque member.

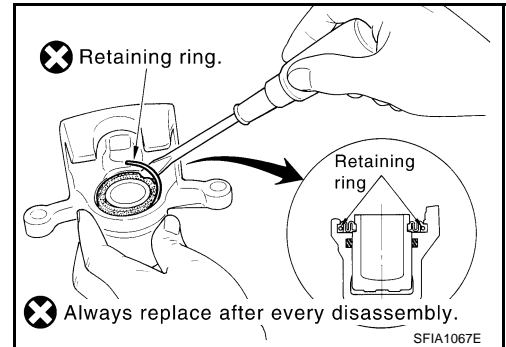

7. Install pad retainers to torque member.
8. After assembling inner shims and inner shim covers to pads, assemble it to torque member.
9. Install cylinder body, and tighten sliding pin bolts to the specified torque.
10. Install brake hose to cylinder body and tighten union bolts to the specified torque.

CAUTION:

- **Assemble brake hose securely to the protrusions on the cylinder body.**

- **Do not reuse copper washer on the union bolts.**

SERVICE DATA AND SPECIFICATIONS (SDS)

SERVICE DATA AND SPECIFICATIONS (SDS)

PPF:00030

General Specifications

AFS0000T

Unit: mm (in)

Front brake	Brake model	CLZ25VD
	Cylinder bore diameter	57.2 (2.252)
	Pad Length × width × thickness	125.6 × 46.0 × 11.0 (4.94 × 1.81 × 0.43)
	Rotor outer diameter × thickness	296 × 24.0 (11.65 × 0.945)
Rear brake	Brake model	AD14VE
	Cylinder bore diameter	42.86 (1.6874)
	Pad Length × width × thickness	97.4 × 33.9 × 10.0 (3.27 × 1.3 × 0.335)
	Rotor outer diameter × thickness	292 × 16 (11.50 × 0.63)
Master cylinder	Cylinder bore diameter	25.4 (1 in)
Control valve	Valve model	Electric brake force distribution
Brake booster	Booster model	V255
	Diaphragm diameter	255 (10.04)
Recommended brake fluid		DOT 3

Brake Pedal

AFS00220

Brake pedal free height (from dash panel top surface)	M/T model	154 - 164 mm (6.06 - 6.46 in)
	A/T model	162 - 172 mm (6.38 - 6.77 in)
Brake pedal depressed height (under a force of 490 N (50 kg, 110 lb) with the engine running)	M/T model	More than 90 mm (3.54 in)
	A/T model	More than 95 mm (3.74 in)
Clearance between stopper rubber and the threaded end of stop lamp switch and ASCD cancel switch.		0.74 - 1.96 mm (0.0291 - 0.0772 in)
Pedal play		3 - 11 mm (0.12 - 0.43 in)

Check Valve

AFS0000V

Vacuum leakage (at vacuum of - 66.7 kPa(- 500 mmHg, - 19.69 inHg))	within 1.3 kpa (10 mmHg, 0.39 inHg) of vacuum for 15 seconds
---	--

Brake Booster

AFS0000W

Vacuum type

Vacuum leakage (at vacuum of - 66.7 kPa (- 500 mmHg, - 19.69 inHg))	Within 3.3 kPa (25 mmHg, 0.98 inHg) of vacuum for 15 seconds
Input rod installation standard dimension	125 mm (4.92 in)

Front Disc Brake

AFS0000X

Brake model		CLZ25VD
Brake pad	Standard thickness (new)	11.0mm (0.433 in)
	Repair limit thickness	2.0 mm (0.079 in)
Disc rotor	Standard thickness (new)	24.0 mm (0.945 in)
	Repair limit thickness	22.0 mm (0.866 in)
	Maximum runout	0.07 mm (0.0028 in)

SERVICE DATA AND SPECIFICATIONS (SDS)

Rear Disc Brake

AFS0000Y

Brake model		AD14VE
Brake pad	Standard thickness (new)	8.5 mm (0.335 in)
	Repair limit thickness	2.0 mm (0.079 in)
Disc rotor	Standard thickness (new)	16.0 mm (0.630 in)
	Repair limit thickness	14.0 mm (0.551 in)
	Maximum runout	0.10 mm (0.0039 in)